



# Instruction Manual

## LeCroy CP150

### Current Probe

November 2005



## Warranty

LeCroy warrants this oscilloscope accessory for normal use and operation within specification for a period of one year from the date of shipment. Spare parts, replacement parts and repairs are warranted for 90 days.

In exercising its warranty, LeCroy, at its option, will either repair or replace any assembly returned within its warranty period to the Customer Service Department or an authorized service center. However, this will be done only if the product is determined by LeCroy's examination to be defective due to workmanship or materials, and the defect is not caused by misuse, neglect, accident, abnormal conditions of operation, or damage resulting from attempted repair or modifications by a non-authorized service facility.

The customer will be responsible for the transportation and insurance charges for the return of products to the service facility. LeCroy will return all products under warranty with transportation charges prepaid.

This warranty replaces all other warranties, expressed or implied, including but not limited to any implied warranty of merchantability, fitness or adequacy for any particular purposes or use. LeCroy shall not be liable for any special, incidental, or consequential damages, whether in contract or otherwise.

### Corporate Headquarters

700 Chestnut Ridge Road  
Chestnut Ridge, NY 10977-6499  
Tel: (845) 578-6020, Fax: (845) 578-5985

**Internet:** [www.lecroy.com](http://www.lecroy.com)

Copyright 2005 by LeCroy Corporation. All rights reserved.

LeCroy, ActiveDSO, ProBus, SMART Trigger, JitterTrack, WavePro, WaveMaster, WaveSurfer, and Waverunner are registered trademarks of LeCroy Corporation. Other product or brand names are trademarks or requested trademarks of their respective holders. Information in this publication supersedes all earlier versions. Specifications subject to change without notice.

Manufactured under an ISO 9000  
Registered Quality Management  
System  
Visit [www.lecroy.com](http://www.lecroy.com) to view the  
certificate

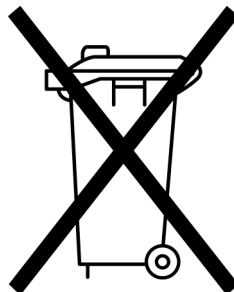

This electronic product is subject to disposal and recycling regulations that vary by country and region. Many countries prohibit the disposal of waste electronic equipment in standard waste receptacles.

For more information about proper disposal and recycling of your LeCroy product, please visit [www.lecroy.com/recycle](http://www.lecroy.com/recycle).

CP150-OM-E Rev C

913689-00 Rev A

## DECLARATION OF CONFORMITY

according to EN ISO/IEC 17050-1:2004

**Manufacturer's Name:** LeCroy Corporation  
**Manufacturer's Address:** 700 Chestnut Ridge Road  
Chestnut Ridge, NY 10977  
USA

herewith declare that

**Product(s) Name:** Current probe  
**Model Number(s):** CP150, CP500

is in conformity with the provisions of the following EC directive(s), including the latest amendments, and with national legislation implementing these directives:

**73/23/EEC Low Voltage Directive**  
**89/336/EEC EMC Directive**

and that conformity with Council Directive 73/23/EEC is based on:

EN 61010-2-032: 2002 Safety requirements for electrical equipment for measurement control and laboratory use  
Part 2-032: Particular requirements for hand-held and hand-manipulated current sensors for electrical test and measurement

and that conformity with Council Directive 89/336/EEC is based on:

EN 61326:1997+A1:1998 EMC requirements for electrical equipment for measurement control and laboratory use  
+A2:2001+A3:2003

Emissions:	EN 55011:1998+A2:2002	Radiated Emissions (Class B)
Immunity:	EN 61000-4-2:1995+A2:2001	Electrostatic Discharge
	EN 61000-4-3: 2002+A1:2003	RF Radiated Electromagnetic Field



**By:** Scott Bausback  
Chief Operating Officer  
**Place:** LeCroy Corporation  
700 Chestnut Ridge Road  
Chestnut Ridge, NY 10977  
USA

**Date:** October 17, 2005

**European Contact:**  
Your local LeCroy Sales Office or  
LeCroy Europe GmbH  
Waldhofer Strasse 104  
D-69123 Heidelberg  
Germany  
Tel: (49) 6221 82700  
Fax: (49) 6221 834655

BLANK PAGE

---

## Table of Contents

	<b>Safety Information .....</b>	<b>1-1</b>
	Operator Safety .....	1-1
	Operating Environment .....	1-1
	Safety Symbols .....	1-1
	Usage .....	1-2
	<b>Overview .....</b>	<b>2-1</b>
	Description .....	2-1
	Key features .....	2-1
	Conventions Used in this Manual .....	2-1
	Accessories .....	2-2
	<b>Operation .....</b>	<b>3-1</b>
	Precautions .....	3-1
	Connecting the Probe to the Test Instrument .....	3-1
	Connecting the Probe to the Test Circuit .....	3-1
	Operation with a LeCroy Oscilloscope .....	3-2
	Auto Zero .....	3-2
	Degauss Probe .....	3-3
	<b>Care and Maintenance .....</b>	<b>4-1</b>
	Cleaning .....	4-1
	Calibration Interval .....	4-1
	Service Strategy .....	4-1
	Troubleshooting .....	4-1
	Returning a Defective Probe .....	4-2
	Returning a Probe to a Different Country .....	4-3
	<b>Performance Verification .....</b>	<b>5-1</b>
	Test Equipment Required .....	5-1
	Preliminary Procedure .....	5-2
	Functional Check .....	5-2
	Performance verification Procedure .....	5-2
	Check DC Accuracy .....	5-3
	<b>Adjustment Procedure .....</b>	<b>6-1</b>
	Test Equipment Required .....	6-1
	Adjustment Procedure .....	6-2

## CP150 Current Probe

---

Preliminary Procedure .....	6-2
Adjust DC Accuracy. ....	6-2
<b>Specifications .....</b>	<b>7-1</b>
Nominal Characteristics .....	7-1
Warranted Characteristics .....	7-1
Typical characteristics .....	7-1
Environmental Characteristics .....	7-2
Physical Characteristics .....	7-2
Graphs .....	7-4
<b>Appendix A .....</b>	<b>A-1</b>
Performance Verification Test Record .....	A-1
Equipment Used: .....	A-1

## Safety Information

# Safety Information

## OPERATOR SAFETY

To avoid personal injury and to prevent damage to the probe or any products connected to it, review the following safety precautions.





## OPERATING ENVIRONMENT

Before using this probe, ensure that its operating environment will be maintained within these parameters:

Operation	In-door Use
Temperature	0 to 40 °C (32 to 104 °F)
Humidity	≤ 80% RH (non-condensing)

## SAFETY SYMBOLS

Whenever the following safety symbols appear in the instruction manual or on the probe, they alert the user to an aspect of safety.

Symbol	Meaning
	Refer to accompanying documents (for safety related information)
<b>CAUTION</b>	Calls attention to a procedure, practice or condition that could possibly cause damage to equipment
<b>WARNING</b>	Calls attention to a procedure, practice or condition that could possibly cause bodily injury or death
	Risk of electrical shock
	Earth ground
	Probe is protected by reinforced or double insulation

## CP150 Current Probe

---

### USAGE

The probe is intended to be used only with instruments that are connected to earth ground through the input connector. The probe is not intended to be used in wet or explosive atmospheres.



The use of the probe and/or the instrument it is connected to in a manner other than that specified may impair the safety mechanisms.



In order to assure safe operation and to obtain maximum performance from the unit, observe the following:

1. To avoid short circuits and accidents that could result in injury or death, use the CP150 current probe only with conductors carrying 600 V (CAT II) or 300 V (CAT III) or less.
2. In order to prevent short circuits and electric shock when conductors being measured carry less than 600 V (CAT II) or 300 V (CAT III) but more than the safe voltage level (SELV-E) make sure that the conductors to be measured are insulated with material conforming to:
  - Overvoltage Category III  
Basic insulation requirement for working voltage of 300 V.
  - Pollution degree 2
3. Never install or remove the probe on bare conductors which are energized. The transformer core and shield are grounded but not insulated and may contact the conductor when the locking lever is open.
4. Be careful not to damage the insulation surface when making measurements.
5. Do not use the probe if any part is damaged. All maintenance should be referred to qualified service personnel.



To guarantee accurate performance characteristics, mechanical shock should be avoided, as well as damage to the cable through excessive bending. The probe case is not sealed and should never be immersed in any fluid. Do not exceed the maximum specified current/voltage levels. (See Specifications).

###



# Overview

## DESCRIPTION

The CP150 uses a combination of Hall effect and transformer technology which enables measurements to be made on AC, DC and impulse currents. It has a 10 MHz bandwidth and is designed to measure continuous peak currents up to 150 Amp.

The probe can be used with a Waverunner®, LC, or WavePro® series oscilloscope with firmware 8.6.0 or higher. With the ProBus® interface, the CP150 becomes an integral part of the oscilloscope. The Auto Zero and Degauss functions are all controlled from the oscilloscope front panel. The oscilloscope provides power to the probe, so no external power supply is needed.

## KEY FEATURES

- Highly accurate current measurements
- Easy current measurements
- Large opening for high current measurements.
- Compact
- Over-current protected

## CONVENTIONS USED IN THIS MANUAL

The following conventions may appear in this manual:

### **Note**

*A Note contains information relating to the use of the product.*

### **CAUTION**

*A Caution contains information that should be followed to avoid possible damage to the instrument or the device under test.*

### **WARNING**

*A Warning alerts you to a potential hazard. Failure to adhere to the statement in a WARNING message could result in personal injury.*

# CP150 Current Probe

---

## ACCESSORIES

Certificate of Calibration

Instruction Manual.

CP150-OM-E

###

# Operation

## PRECAUTIONS

### Note

*The sensor head is a precision assembly consisting of a molded component with a ferrite core and a Hall effect element. It may be damaged if subjected to sudden changes in temperature, mechanical strain or shock.*

*The mating surfaces of the sensor are precision ground and should be treated with care. If there is any type of dust or dirt on the mating surfaces of the sensor head, measurements may be impaired.*

### Note

*Accurate measurements may not be possible in locations subject to strong magnetic fields such as transformers and high-current conductors, or in locations subject to strong external electric fields.*

## CONNECTING THE PROBE TO THE TEST INSTRUMENT

The CP150 probe has been designed for use with the Waverunner, LC, and WavePro series LeCroy oscilloscopes equipped with the ProBus interface. Attach the probe output connector to the oscilloscope input connector. The oscilloscope will recognize the probe, set the oscilloscope input termination to 1 M $\Omega$  and activate the probe control functions in the user interface.

## CONNECTING THE PROBE TO THE TEST CIRCUIT

The CP150 has been designed with a movable split core eliminating the need to break the conductor for the core to slip around the conductor.

To Connect:

1. Pull the slider, so that the clamp opens.
2. Align the sensor so that the current direction indicator corresponds to the direction of current flow in the conductor.
3. Press the probe jaws closed around the conductor until jaws click shut.

## CP150 Current Probe

---

4. Close the slider on the sensor head until the "UNLOCK" indication disappears and the "LOCK" indication appears.

### Note

*Never use this probe on bare conductors. The core and shield are grounded and any voltage applied to the conductor may cause damage to the probe or the circuit under test.*

## OPERATION WITH A LECROY OSCILLOSCOPE

Control through the oscilloscope user interface can be found in the **Coupling** menu of the channel to which the probe is connected.

Turning the **VOLTS/DIV** knob will control the oscilloscope's scale factor to give full dynamic range from 200 mA/div to 100 A/div.

Figure 3-1A shows the oscilloscope user interface menu for a CP150 probe. The menu allows for the selection of the probe's input coupling (**DC** or **Grounded**) in the **COUPLING** menu and the **AUTO ZERO** and **DEGAUSS PROBE** functions.

## AUTO ZERO

The CP150 incorporates an Auto Zero function to remove the DC offset from the current probe. Auto Zero must be invoked by the user.

After several minutes of warm-up, or when the probe is exposed to a large shift in ambient temperature, some DC offset drift may occur. To initiate an Auto Zero cycle press the button next to **AUTO ZERO** menu in the oscilloscope's user interface.

## Operation

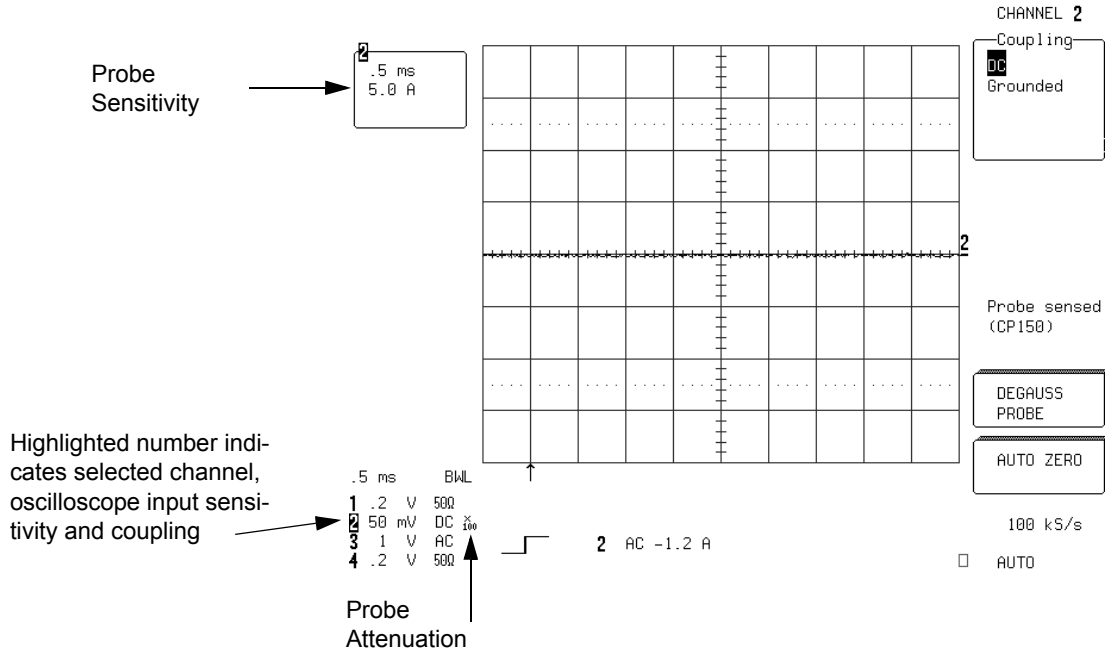

Figure 3-1. Oscilloscope display with menu

### DEGAUSS PROBE

If the probe has been magnetized by external magnetic field or by excessive input, the core can be demagnetized by pressing the button next to **DEGAUSS PROBE** menu.

The demagnetizing process takes about 1 second and should always be performed before taking a measurement.

Without clamping the probe around a conductor, slide the opening lever to close and lock the probe.

An Auto Zero is automatically performed as part of the degauss cycle.

###

## CP150 Current Probe

---

BLANK PAGE

## Care and Maintenance

# Care and Maintenance

## CLEANING

The exterior of the probe and cable should be cleaned only using a soft cloth moistened with water or isopropyl alcohol. The use of abrasive agent, strong detergents or other solvents may damage the probe.



### CAUTION

*The probe case is not sealed and should never be immersed in any fluid.*

## CALIBRATION INTERVAL

The recommended calibration interval is one year. Adjustment should only be performed by qualified personnel. (A Performance Verification / Adjustment procedure is included in this manual.)

## SERVICE STRATEGY

Defective probes must be returned to a LeCroy service facility for diagnosis and exchange. A defective probe under warranty will be replaced with a factory refurbished probe. A probe that is not under warranty can be exchanged for a factory refurbished probe. A modest fee is charged for this service. A defective probe must be returned in order to receive credit for the probe core.

## TROUBLESHOOTING

If the probe is not operating properly the problem may be the way in which it is used. Before assuming the probe is defective, perform the following troubleshooting procedures:

1. Verify using on a LT or LC series LeCroy oscilloscope with firmware 8.6.0 or higher. (Firmware version of your oscilloscope can be verified by pushing **SCOPE STATUS** and then selecting **System** menu option.
2. Waveform is inverted — Make sure the arrow on the slider is in the direction of the current flow.
3. No signal — Make sure the slider is closed and locked.
- 4.

## CP150 Current Probe

---

### RETURNING A DEFECTIVE PROBE

The procedure for returning a defective probe is as follows:

Contact your local LeCroy sales representative to find out where to return the product. All returned products should be identified by model number and serial number. Provide your name and contact number and if possible describe the defect or failure. In case of products returned to the factory, a Return Authorization Number (RAN) should be used. The RAN can be established by contacting your nearest LeCroy office, or the New York Customer Care Center.

Return shipment should be prepaid. LeCroy cannot accept COD or Collect Return shipments. We recommend air-freighting.

#### **Note**

*It is important that the RAN be clearly shown on the outside of the shipping package for prompt redirection to the appropriate department.*

1. Contact your local LeCroy sales or service representative to obtain a Return Authorization Number.
2. Remove all accessories from the probe. Do not include the manual.
3. Pack the probe in its case, surrounded by the original packing material (or equivalent) and box.
4. Label the case with a tag containing:
  - The RAN
  - Name and address of the owner
  - Probe model and serial number
  - Description of failure
5. Package the probe case in a cardboard shipping box with adequate padding to avoid damage in transit.
6. Mark the outside of the box with the shipping address given to you by the LeCroy representative; be sure to add the following:
  - ATTN: <RAN assigned by the LeCroy representative>
  - FRAGILE



## Care and Maintenance

---

7. Insure the item for the replacement cost of the probe.
8. Ship the package to the appropriate address.

### RETURNING A PROBE TO A DIFFERENT COUNTRY

In order to avoid customs duty for purchase price of a new probe or accessory, when your probe is returned for service, please use the following procedure.

In addition to the items mentioned above in 'Returning a defective probe', you'll need to mark shipments returned for service as a 'Return of US manufactured goods for warranty repair/recalibration'. If there is a cost involved in the service, put the cost of the service in the value column and the original value of the product at time of purchase in the body of the invoice marked 'For insurance purposes only'. Be very specific as to the reason for shipment.

Duties may have to be paid on the value of the service.

####

## CP150 Current Probe

---

BLANK PAGE

## Performance Verification

### Performance Verification

This procedure can be used to verify the warranted characteristics of the CP150 Current Probe.

The recommended calibration interval for the model CP150 Current Probe is one year. The complete performance verification procedure should be performed as the first step of annual calibration. Test results can be recorded on a photocopy of the Test Record provided at the end of the manual.

Performance verification can be completed without removing the probe covers or exposing the user to hazardous voltages. Adjustment should only be attempted if a parameter measured in the Performance Verification Procedure is outside the specification limits.

Adjustment should only be performed by qualified personnel.

#### TEST EQUIPMENT REQUIRED

The following table lists the test equipment and accessories (or their equivalents) which are required for performance verification of the CP150 Current Probe.

Because the input and output connector types may vary on different brands and models of test instruments, additional adapters or cables may be required.

**Table 5-1. List of Required Equipment**

Description	Minimum Requirements	Test Equipment Examples
Wide Band Oscilloscope	ProBus interface equipped Software version 8.6.0 or higher	LeCroy LT322
Digital Multimeter (2 required)	DC: 0.1% Accuracy 5½ digit resolution	Agilent Technologies 34401A or Fluke 8842A-09
Function Generator	50 Hz sine wave output. 3.55 Vrms into 50Ω	Agilent Technologies 33120A or Stanford Research Model DS340
Calibration Fixture, 500 Turn Loop	500 Turn loop in series with 0.5Ω ±0.1% resistor with sense terminals.	LeCroy CP150-CF02
Calibration Fixture	ProBus Extender Cable	LeCroy PROBUS-CF01

## CP150 Current Probe

Description	Minimum Requirements	Test Equipment Examples
Banana Plug Adapter	Female BNC to Dual Banana Plug	Pomona 1269
Patch Cables (4 required)	Male Banana to Male Banana, 12"	Pomona B-12-0 (black), B-12-2 (red)
BNC Adapter	BNC Male to Dual Banana Jack	Pomona 1296

### PRELIMINARY PROCEDURE

1. Connect the CP150 to the channel 1 input of the oscilloscope and completely close the probe slider.
2. Turn the oscilloscope on and allow at least 30 minutes warm-up time for the CP150 and test equipment before performing the Verification Procedure.
3. Turn on the other test equipment and allow these to warm up for the time recommended by the manufacturer.
4. While the instruments are reaching operating temperature, make a photocopy of the Performance Verification Test Record (located in Appendix A), and fill in the necessary data.

### FUNCTIONAL CHECK

The functional check will verify the basic operation of the probe functions.

It is recommended the Functional Check be performed prior to the Performance Verification Procedure.

1. Select Channel 1 and enter the **Coupling** menu.
2. Verify that **Probe sensed (CP150)** is displayed on the right hand menu.
3. Degauss the probe by pressing the **DEGAUSS** button, (located on the coupling menu), twice.
4. Verify that "Degaussing CP150 probe...." is displayed at the top of the screen and no error message remains displayed.

### PERFORMANCE VERIFICATION PROCEDURE

The warranted characteristics of the CP150 Current Probe are valid at any temperature within the Environmental Characteristics listed in the Specifications. However, some of the other test

## Performance Verification

equipment used to verify the performance may have environmental limitations required to meet the accuracy needed for the procedure. Make sure that the ambient conditions meet the requirements of all the test instruments used in his procedure.

### Note

The correct operation of the CP150 controls requires software version 8.6.0 or higher. The software version in the test oscilloscope can be verified by pushing **SCOPE STATUS**, then selecting the **System** menu option. Contact your local LeCroy representative if the software in your oscilloscope requires updating.

### CHECK LF ACCURACY

1. Set the Function generator to 50 Hz sine wave. Output voltage at 1.7 Vrms with 50Ω output.

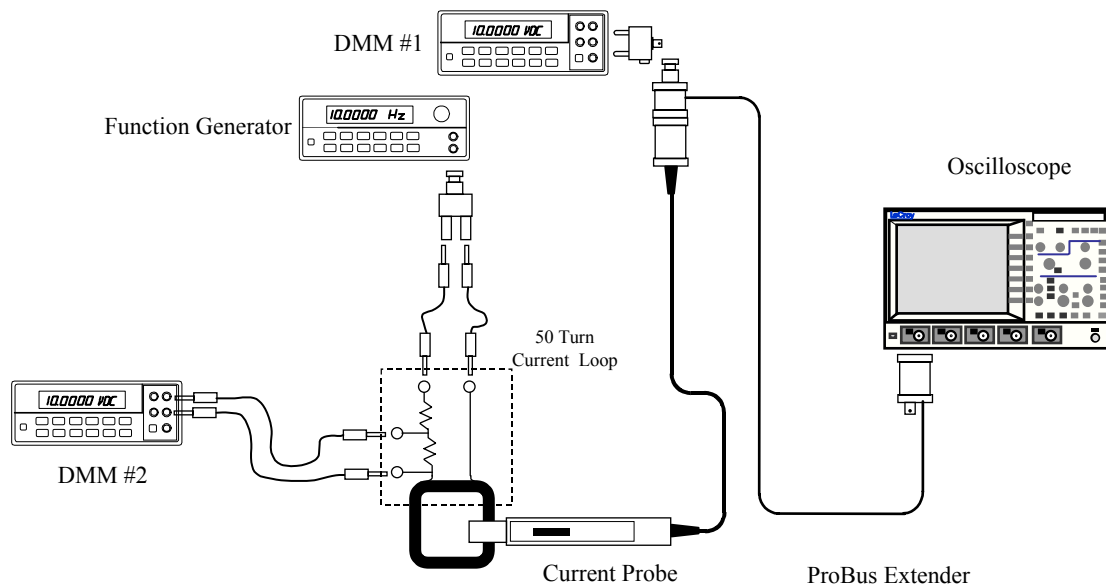

Figure 5-1. LF Accuracy Test Set Up

2. Remove the CP150 from the oscilloscope and reconnect using the ProBus extension cable. Connect the BNC male connector of the ProBus extension to DMM #1 using a BNC Female to Dual Banana adapter.

## CP150 Current Probe

---

3. Using the banana patch cords and the BNC to Dual Banana Plug Adapter, connect the 'V Source' and 'V Return' terminals of the 50 Turn Calibration Loop to the output of the Function Generator. (Figure 5-1)
4. Connect the Current Sense terminals of the 500 Turn Calibration Loop to the voltage inputs of DMM #2.
5. Set both DMMs to measure AC Volt.
6. With the CP150 removed from any signal and the slider returned to the LOCKED position, degauss the probe by pressing the **DEGAUSS** button (located on the coupling menu) twice.
7. Open the CP150 slider and position the probe input around the 500 Turn loop. Close and LOCK the slider.
8. Adjust the Function generator voltage until the voltage measured at the 'Current Sense' terminals (DMM #2) reads  $10 \text{ mV} \pm 0.01 \text{ mV}$ . (This corresponds to 10 A at the probe head).
9. Record the voltage measured by DMM #1 on the Test Record.
10. Verify that the measured voltage is between 99 mV and 101 mVolt.

###

## Adjustment Procedure

# Adjustment Procedure

This procedure can be used to adjust the warranted characteristics of the CP150 Current Probe. This procedure should be used if a parameter measured in the Performance Verification Procedure is outside of the specification limits.

Adjustment should only be performed by qualified personnel.

### TEST EQUIPMENT REQUIRED

The following table lists the test equipment and accessories, or their equivalents, which are required for adjustment of the CP150 Current Probe.

Because the input and output connector types may vary on different brands and models of test instruments, additional adapters or cables may be required.

**Table 6-1. List of Required Equipment**

Description	Minimum Requirements	Test Equipment Examples
Wide Band Oscilloscope	ProBus interface equipped Software version 8.6.0 or higher	LeCroy LT322
Digital Multimeter (2 required)	DC: 0.1% Accuracy 5½ digit resolution	Agilent Technologies 34401A, or Fluke 8842A-09
Function Generator	50 Hz sine wave output. 3 Vrms into 50 Ω	Agilent Technologies 33120A, or Stanford Research Model DS340
Calibration Fixture, 50 Turn Loop	500 Turn loop in series with 0.5 Ω ±0.1% resistor with sense terminals.	LeCroy CP150-CF02
Calibration Fixture	ProBus Extension Cable	LeCroy PROBUS-CF01
Banana Plug Adapter	Female BNC to Dual Banana Plug	Pomona 1269
Patch Cables (4 required)	Male Banana to Male Banana, 12"	Pomona B-12-0 (black), B-12-2 (red)
BNC Adapter	BNC Male to Dual Banana Jack	Pomona 1296
Double-sided tape	Adhesive tape to re-attach probe label	Scotch Double Stick Tape 0.5" wide

## CP150 Current Probe

### ADJUSTMENT PROCEDURE



The warranted characteristics of the CP150 Current Probe are valid at any temperature within the Environmental Characteristics listed in the Specifications. However, some of the other test equipment used to verify the performance may have environmental limitations required to meet the accuracy needed for the procedure. Make sure that the ambient conditions meet the requirements of all the test instruments used in this procedure.

**Note:**

*The correct operation of the controls of the CP150 requires oscilloscope software version 8.6.0 or higher. The software version in the test oscilloscope can be verified by pushing **SCOPE STATUS**, then selecting the **System** menu option. Contact your local LeCroy representative if the software in your oscilloscope requires updating.*

### PRELIMINARY PROCEDURE

1. Remove the light blue product label from the probe head to expose three variable resistors. Remove the old adhesive from the label and probe head.
2. Connect the CP150 to the channel 1 input of the oscilloscope through the ProBUS extension cable, and close and lock the probe jaws.
3. Turn the oscilloscope on and allow at least 30 minutes warm-up time for the CP150 and test equipment before performing the Verification Procedure.

### ADJUST LF ACCURACY.

1. Set the Function Generator to 50 Hz, sinewave output at 1.7 Vrms with 50  $\Omega$  output.
2. Connect BNC male of ProBus extension to DMM #1 using BNC Female to Dual Banana adapter.
3. Using banana patch cords, connect the 'V Source' and 'V Return' terminals of the 500 Turn Calibration Loop, to the output of the Function Generator using the BNC to Dual Banana plug adapter Output. (Refer to Figure 6-1)



## Adjustment Procedure

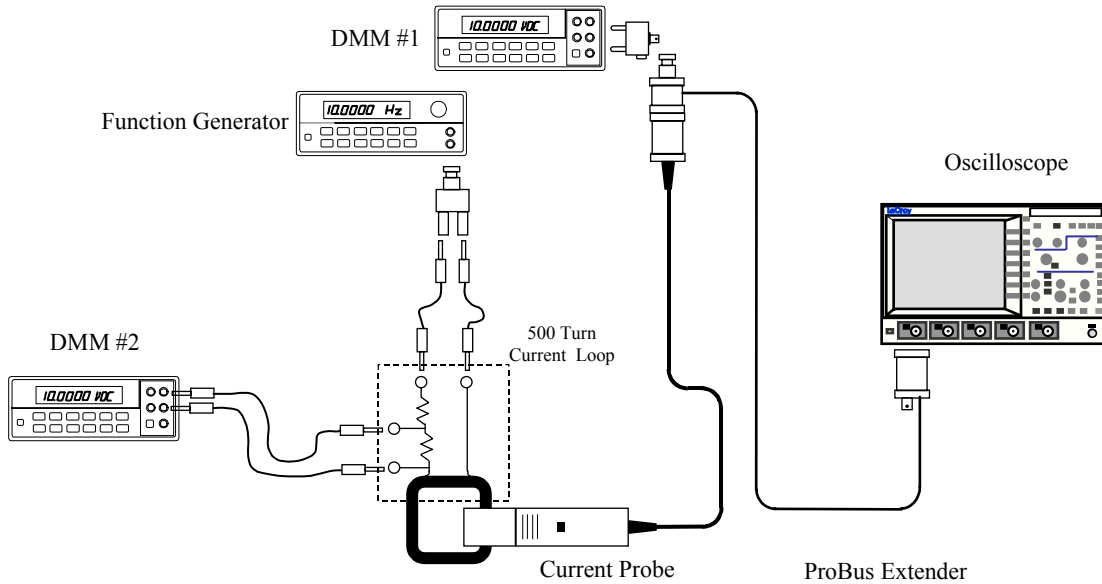

**Figure 6-1. LF Accuracy Adjustment Set Up**

4. Connect the Current Sense terminals of the 500 Turn Calibration Loop to the voltage inputs of DMM #2
5. Set both DMMs to measure AC Volt.
6. With the CP150 removed from any signal and the slider returned to the LOCKED position, degauss the probe by pressing the **DEGAUSS** button on the oscilloscope, (located on the coupling menu), twice.
7. Open the CP150 jaws and position the probe input around the 500 Turn loop. Close and LOCK the slider.
8. Adjust the Function Generator voltage until the voltage measured at the 'Current Sense' terminals (DMM #2) is  $10 \text{ mV} \pm 0.01 \text{ mV}$ . (This corresponds to 10 A at the probe head).
9. Adjust the center variable resistor on the probe head until the voltage measured on DMM #1 is close to 10X the voltage measured on DMM #2.
10. Verify that the measured voltage is between 99 mV and 101 mV.
11. Disconnect the probe from the test set-up.

## CP150 Current Probe

---

12. Re-apply the light blue product label to the probe head using the double-sided tape.

###

## Specifications

# Specifications

### NOMINAL CHARACTERISTICS

Nominal characteristics describe parameters and attributes that are guaranteed by design, but do not have associated tolerances.

Maximum Continuous Input Current	150 Amp rms Refer to Figure 7-1, "Input Current vs. Frequency."
Maximum Non-Continuous Peak Current	300 Amp peak, 500 Amp at pulse width of < 30 $\mu$ sec.
Insertion Impedance	Refer to Figure 7-2.
Intended Output Load	1 M $\Omega$
Maximum Permitted Circuit Voltage	600 V Cat II, 300 V Cat III (Insulated conductor)

### WARRANTED CHARACTERISTICS

Warranted characteristics describe parameters that have guaranteed performance. Unless otherwise noted, tests are provided in the Performance Verification Procedure for all warranted specifications.

Guaranteed at 23  $^{\circ}$ C  $\pm$ 3  $^{\circ}$ C (73  $^{\circ}$ F  $\pm$ 5  $^{\circ}$ F) after power has been applied for 30 minutes.

Low Frequency Accuracy  $\pm$ 1.0% of reading  $\pm$ 100 mA.

### TYPICAL CHARACTERISTICS

Typical characteristics describe parameters which do not have guaranteed performance, however are representative of the average performance from a sample of several probes. Tests for typical characteristics are not provided in the Performance Verification procedure.

Sensitivity*	200 mA/div* to 100 A/div
Output voltage	0.01 V/A

\* Lower sensitivity may change with different oscilloscope models.

## CP150 Current Probe

Sensitivity Temperature	±2% or less. (from 0° to +40 °C, 32 °F to 104 °F).
Noise	Equivalent to 25 mA rms or less (Bandwidth of measuring instrument: 20 MHz).
Bandwidth	DC to 10 MHz
Rise Time	≤ 35 ns

## ENVIRONMENTAL CHARACTERISTICS

Temperature: Operating	0 to 40 °C (32 °F to 104 °F) at 80% relative humidity
Storage	-10 °C to 50 °C (14 °F to 122 °F) 80% relative humidity.
Usage	Indoor
Altitude	2000 m (6562 feet)
Effect of External Magnetic Field	Equivalent to a maximum of 150 mA (in a DC or 60 Hz, 400 A/m magnetic field)

## PHYSICAL CHARACTERISTICS

Dimensions Probe:	
Length	176 mm (6.9 in.)
Width	27 mm (1.1 in.)
Height	69 mm (2.7 in.)
Dimensions Compensation Box:	
Length	65 mm (2.6 in.)
Width	39 mm (1.5 in.)
Height	24 mm (0.9 in.)
Weight	460 g (16.2 oz.)
Maximum conductor diameter	20 mm (0.79 in.)

## Specifications

### COMPLIANCES AND CERTIFICATIONS

#### CE Declaration of Conformity

The probe meets requirements of the EMC Directive 89/336/EEC for Electromagnetic Compatibility and Low Voltage Directive 73/23/EEC for Product Safety.

EMC Directive: EN 61326:1997+A1:1998+A2:2001+A3:2003  
EMC requirements for electrical equipment for measurement, control and laboratory use

Electromagnetic Emission: EN 55011:1998+A2:2002  
Radiated Emissions (Class B)

Electromagnetic Immunity: EN 61000-4-2:1995+A2:2001\*  
Electrostatic Discharge (4 kV/8 kV contact/air)

EN 61000-4-3:2002+A1:2003\*  
RF Radiated Electromagnetic Field (3 V/m)

Low Voltage Directive: EN 61010-2-032:2002  
Safety requirements for electrical equipment for measurement control and laboratory use.  
Part 2-032: Particular requirements for hand-held and hand-manipulated current sensors for electrical test and measurement

The probe has been qualified to the following limits:  
Measurement Category II, III (anticipated transient voltage 4000 V)  
Pollution Degree 2

\*Meets Performance Criteria "B" limits at certain test levels, during the disturbance, product undergoes a temporary degradation or loss of function of performance which is self recoverable.

# CP150 Current Probe

## GRAPHS

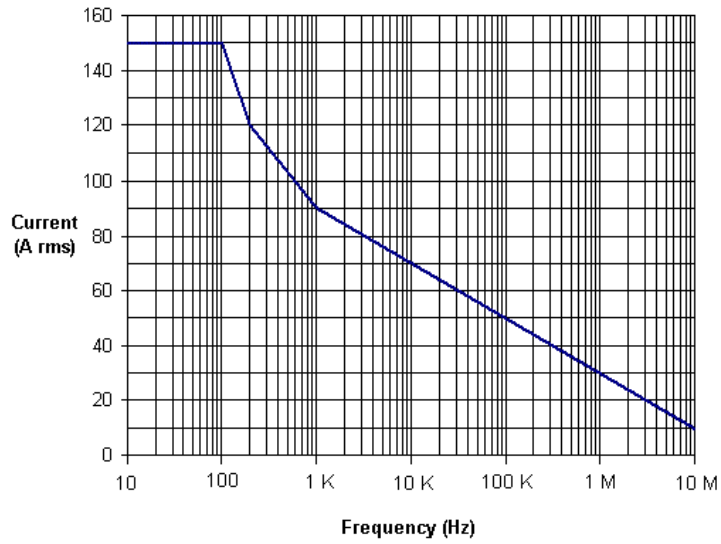

Figure 7-1. Maximum Input Current vs. Frequency

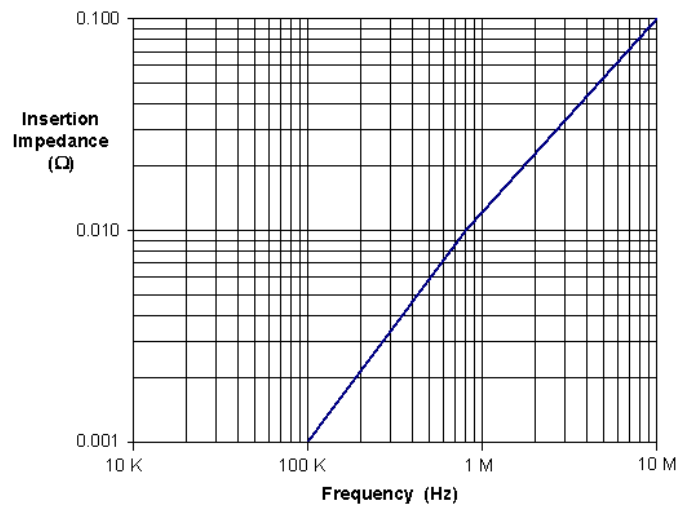

Figure 7-2. Insertion Impedance vs. Frequency

###

**Appendix A**

**Appendix A**

**PERFORMANCE VERIFICATION TEST RECORD**

This record can be used to record the results of measurements made during the performance verification of the CP150 Current Probe.

Photocopy this page and record the results on the copy. File the completed record as required by applicable internal quality procedures.

The section in the test record corresponds to the parameters tested in the performance verification procedure. The numbers preceding the individual data records correspond to the steps in the procedure that require the recording of data. Results recorded in the column labeled "Test Result" are the actual specification limit check. The test limits are included in all of these steps. Other measurements and the results of intermediate calculations that support the limit check are to be recorded in the column labeled "Intermediate Results".

Permission is granted to reproduce these pages for the purpose of recording test results.

**Model:** \_\_\_\_\_

**Serial Number:** \_\_\_\_\_

**Asset or Tracking Number:** \_\_\_\_\_

**Date:** \_\_\_\_\_

**Technician:** \_\_\_\_\_

**EQUIPMENT USED:**

	MODEL	SERIAL NUMBER	CALIBRATION DUE DATE
<b>Digital Multimeter #1</b>			
<b>Digital Multimeter #2</b>			
<b>Function Generator<sup>1</sup></b>			N/A

<sup>1</sup>The function generator used in this Performance Verification Procedure is used for making relative measurements. The output of the generator is measured with a DMM or oscilloscope in this procedure. Thus, the generator is not required to be calibrated.

# CP150 Current Probe

---

## CP150 TEST RECORD

Step	Description	Test Result
<b>Gain Accuracy</b>		
10	Probe Output (Spec limit: 99 - 101 mV)	_____ V

###